

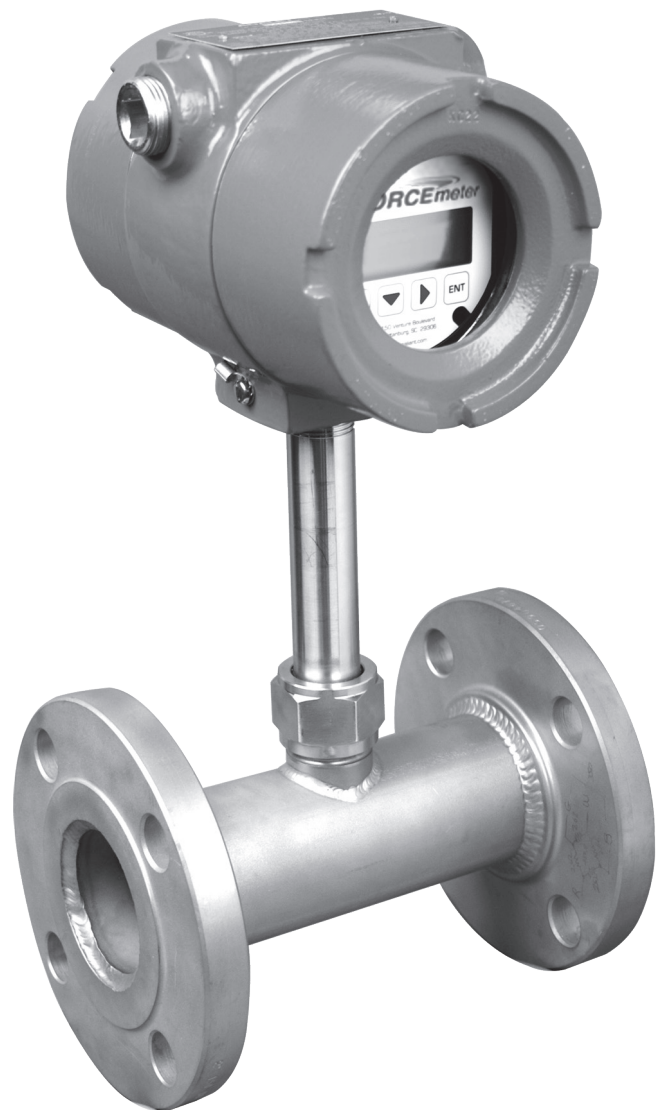

# ForceMeter™ Strain Gage Installation & Operation Manual





# ForceMeter™ Strain Gage Installation & Operation Manual

## CONTENTS

<b>Section I: INTRODUCTION .....</b>	<b>1</b>
<b>Section II: APPLICATIONS .....</b>	<b>1</b>
STEAM	
BIDIRECTIONAL	
<b>Section III: PRINCIPLE OF OPERATION .....</b>	<b>2</b>
FIGURE 1. Four Arm Bridge Circuit	
FIGURE 2. Equivalent Forces	
<b>Section IV: SPECIFICATIONS.....</b>	<b>4</b>
FIGURE 3. Specifications & Accessories	
<b>Section V: INSTALLATION .....</b>	<b>5</b>
INLINE & INSERTION MOUNTING	
FIGURE 4. Wafer, 150# RF & MNPT	
INSERTION PROBE MOUNTING	
FIGURE 5. Flange Bolt Hole Configuration	
FIGURE 6. Fixed Insertion	
RETRACTABLE MOUNTING	
FIGURE 7. Retractable Pipe Mounting	
FIGURE 8. Parts List	
<b>Section VI: ELECTRICAL.....</b>	<b>10</b>
INTEGRAL TRANSMITTER	
FIGURE 9. Integral Transmitter Wiring	
REMOTE TRANSMITTER	
FIGURE 10. Remote Wiring	
HART COMMUNICATION	
FIGURE 11. HART Wiring	

# CONTENTS, contd.

## **Section VII: TRANSMITTER MENU OPTIONS ..... 13**

- DISPLAY
- ZEROING MODE
- RESETTING TOTAL MODE
- ACCESSING SIMULATE MODE
- ACCESSING PROGRAM MODE

## **Section VIII: PROGRAM MODE INFORMATION..... 16**

- FLOW TYPE
- RATE UNIT
  - FIGURE 12. Rate Options for Volumetric Flow
  - FIGURE 13. Rate Options for Mass Flow
- TOTAL UNIT
  - FIGURE 14. Total Options for Volumetric Flow
  - FIGURE 15. Total Options for Mass Flow
- RANGE SET
- CUSTOM SCALE
- SET CAL
- DECIMAL
- SPECIAL
- BIDIRECT

## **Section IX. CALIBRATION..... 19**

- FIELD CALIBRATION

## **Section X: TROUBLESHOOTING..... 21**

- FIGURE 16. Fault Codes

## **Section XI: MAINTENANCE & REPAIR..... 22**

## **Section XII: WARRANTY ..... 22**

## **Section XIII: APPENDICES..... 23**

1. THEORY
2. VISCOSITY
3. CORRECTION FACTORS FOR VOLUMETRIC GAS FLOW
4. CORRECTION FACTORS FOR STEAM FLOW RATE
5. CORRECTIONS FOR CHANGE IN FORCEMETER™ SENSITIVITY



## I. INTRODUCTION

The ForceMeter™ is available in a wide variety of sizes, materials, connections and flow ranges. It is a universal flow meter due to its effectiveness with liquids, gas, and steam, both superheated and saturated. Typical accuracies are of 1% of rate over a 15:1 turndown.

## II. APPLICATIONS

ForceMeter™ are used to measure liquids, gas, or steam having sufficient momentum to exert enough force on the target for the sensing system to operate. This can include mild slurries. Special units with air purges have been used where particulates greater than 0.026 inches are in the flow stream.

### STEAM

The strain gage target flow meter has all the features desired in a saturated or super-heated steam flow meter. It has an all-welded design, which eliminates potential leak paths created by seals, gaskets, or o-rings. It has a low-pressure drop, no moving parts (bearings, springs), and is not damaged by slugs of condensate. The retractable flow version allows the flow meter to be inserted into service without shutting off the stream of flow. Seasonal flow ranges, such as large flow rates in the winter and small flow rates in the summer, can be easily obtained by changing targets.

### BI-DIRECTIONAL

The strain gage bridge circuit technology, which measures the force produced by flow, will measure both forward and reverse force. The polarity of the output signal indicates the direction of the flow, making the target meter a true bi-directional flow meter. A special target is used to ensure accuracy in both directions.

### III. PRINCIPLE OF OPERATION

The ForceMeter™ provides flow measurement by sensing the fluid force acting on the target suspended in the flow stream. The following equation describes the operation of the strain gage target flow meter:

$$\text{Force} = C_d A \rho \frac{V^2}{2g}$$

- C<sub>d</sub> = Overall drag coefficient obtained from empirical data
- A = Target area
- ρ = Fluid density
- V = Fluid velocity at the point of measurement
- g = Gravitational force of the earth

In a given flow application, the drag coefficient, target area, and gravitational force would be constant. The flow meter is actually measuring the following:

$$\text{Fluid density} \times \text{fluid velocity}^2$$

Flow is equal to the square root of the force. The transmitter amplifies the output signal, extracts the square root, and produces a linear analog (4-20ma) output with HART communication.

A typical strain gage target flow meter consists of the sensing element, mounting flange or housing, and a terminal strip or transmitter enclosed in a junction box.

The sensing element consists of a wiring connector, target rod, calibrated target, mounting base, protective case, and the sensing tube where the actual strain gages are attached.

Four strain gages (variable resistors) are attached to the sensing tube, two on the leading side of flow, and two on the trailing side of flow. The strain gages are inter-connected, forming a four active arm strain gage bridge circuit. At zero flow (no force on the target), the bridge circuit is balanced, producing zero output. Flow produces a strain on the sensing tube, compressing the leading side strain gages and tensing the trailing side strain gages, causing their resistance to decrease and increase respectively. The change in resistance of the strain gages offsets the bridge circuit, producing an output.

**FIGURE 1. FOUR ARM BRIDGE CIRCUIT**

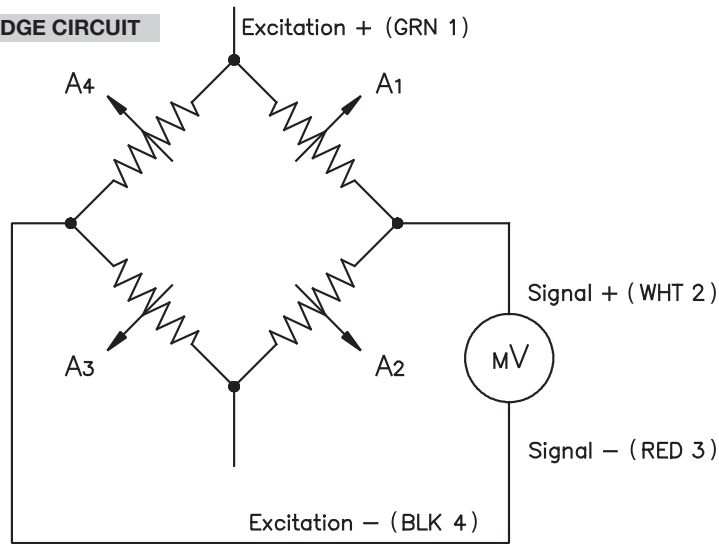

The calibration and range of the flow meter is determined by the target size. Given the flow parameters for an application and knowing the desired amount of stress to be applied to the sensing tube at full-scale flow, the approximate target size is determined. The flow meter is then tested in a flow test stand and the final target is obtained.

All fluid flow application can be mathematically converted to a water flow equivalent. This water flow equivalent represents the same force as the actual fluid application allowing water to be used as the primary calibration medium. The following applications all exert the same force on the target, producing the same bridge output:

**FIGURE 2. EQUIVALENT FORCES**

FLUID	SIZE	FLOW RATE	PSIG	DEGREE (F)
Saturated Steam	3"	3460 PPH	120	+350°
Air	3"	1080 SCFM	100	+70°
Water	3"	100 GPM	75	+45°
Liquid Nitrogen	3"	750 PPM	20	-300°

## IV. SPECIFICATIONS

The sensing element, the heart of the flow meter, can be installed in any line size and in almost any mounting configuration. Inline flow meters, supplied with mounting housing such as wafer, flanged, MNPT, and flare tube, are available for one half to six inch line sizes. Fixed insertion type flow meters are available for line sizes of four to sixty inches. Retractable insertion type flow meters are available for line sizes of four to thirty six inches.

The type of mounting configuration limits the pressure rating of the flow meter. In flow meters that have a flange, the flange determines the maximum operating pressure. The strain gage sensing element is available in three pressure ratings: 1000, 5000 and 10,000 PSIG. The meter is available in three temperature ranges, from -65° to +425° F, -65° to +500° F, and -320° to +250° F.

**FIGURE 3. SPECIFICATIONS & ACCESSORIES**

FUNCTIONAL SPECIFICATIONS	
Fluid Types	Liquids (Reynolds numbers greater than 2000), gases and steam
Bridge Resistance	5000 ohms ± 30 ohms
Operating Pressure	Sensing Element: 1000, 5000, or 10,000 PSI Mounting Type / Connections: according to the appropriate ANSI specifications
Operating Temperature	-65° to 425° F (-54° to 218° C) standard -65° to 500° F (-54° to 260° C) extended temp -320° to 250° F (-195° to 121° C) cryogenic
Transmitter Temperature	-4° to 158° F (-20° to 70° C)
PERFORMANCE SPECIFICATIONS	
Accuracy	± 1.0% of rate
Repeatability	± 0.15% of rate
Turn Down	15:1
Response Time	0.33 mS
Damping	User adjustable settings 0 to 99 samples
Flow Direction	Unidirectional or bidirectional
Approvals	CE Electromagnetic Compatibility Directive (EMC) 2004/108/EC FM (Canada & US): XP Class I, Div 1, Groups B, C, D DIP Class II & III, Div 1, Groups E, F, G Intrinsically Safe
PHYSICAL SPECIFICATIONS	
Housing / Flanges	316L stainless steel (standard), others available
Mounting Positions	Horizontal, vertical or on an angle
Typical Straight Pipe Requirements	10 x the pipe diameter of straight uninterrupted pipe upstream 5 x the pipe diameter of straight uninterrupted pipe downstream
Process Connections	MNPT (0.5" to 3.0") ANSI Raised Face Flange (Class 150# standard, 0.5" to 6.0") Wafer (0.5" to 6.0") AN 37 Degree Flare Tube (0.5" to 2.0") Fixed Insertion Probes, 2" or 4" ANSI Raised Face Flange (Class 150# standard) Retractable Insertion Probes, 2" or 4" ANSI Raised Face Flange (Class 150# standard)
Transmitter Housing	Integral: Polyester powder coated aluminum, dual cavity Remote: Compression-molded fiberglass Remote Hazardous: Polyester powder coated aluminum, dual cavity
Power	18-36 VDC
Line Sizes	Inline 0.5" to 6.0", Insertion 4.0" to 60"
Electrical Connections	0.75" NPT
ACCESSORIES	
	Rate / Total Indicator, Batch Controller, Mass Flow Computer (gases or steam)

## V. INSTALLATION

**CAUTIONS:** Care should be exercised in removing the ForceMeter™ from its packing crate or carton and in installing it in the line. Do not damage sealing surfaces such as flange gasket surfaces and pipe threads. Avoid lifting the ForceMeter™ by the target (disc) or target lever rod. Avoid damage to the target.

### MOUNTING

The ForceMeter™ should be installed on the upstream side of any flow controls or shut off valves to insure complete immersion of the target in the fluid at all rates of flow.

The meter must typically be preceded by at least ten diameters of straight, uninterrupted flow line and followed by a minimum of five diameters. Do not precede the instrument with flexible corrugated tubing. Some applications require a minimum of twenty diameters and followed by a minimum of ten diameters of straight uninterrupted flow line. "Pipe diameter" is the straight length of pipe divided by the nominal pipe size.

There are up and down stream piping requirements due to velocity profile and Reynolds Number. The requirements vary depending on size, piping, and distances from elbows, pumps, or control valves.

### INLINE

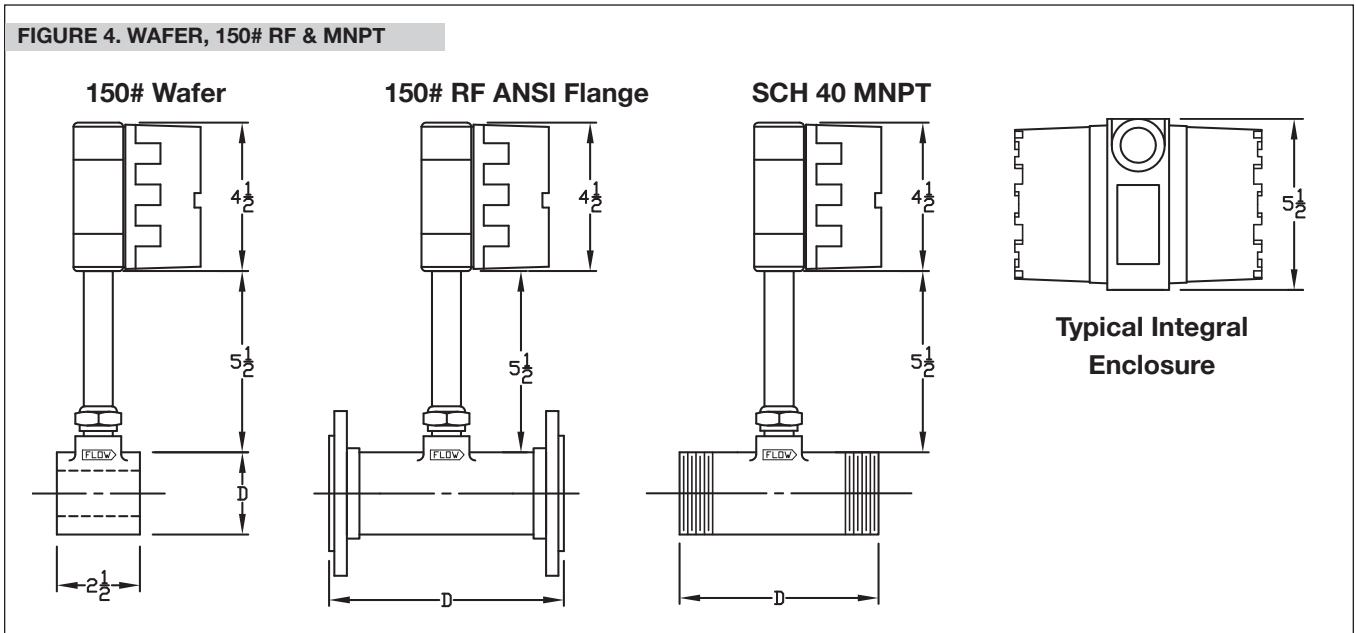



### INSERTION PROBE MOUNTING

A flanged stub must be fabricated on the pipeline. Either a 2" or 4" ANSI flange is required. Refer to the meter model number on the data sheet for the flange size and rating. **FIGURES 5. FLANGE BOLT HOLE CONFIGURATION** demonstrates the dimensions of the stub and orientation of the flange bolt holes. The inside configuration of this stub must be as shown on the drawing to permit the target to be inserted and withdrawn without interference. To guarantee target alignment, be sure the flange bolt holes straddle the pipe centerline.

**FIGURE 5. FLANGE BOLT HOLE CONFIGURATION**

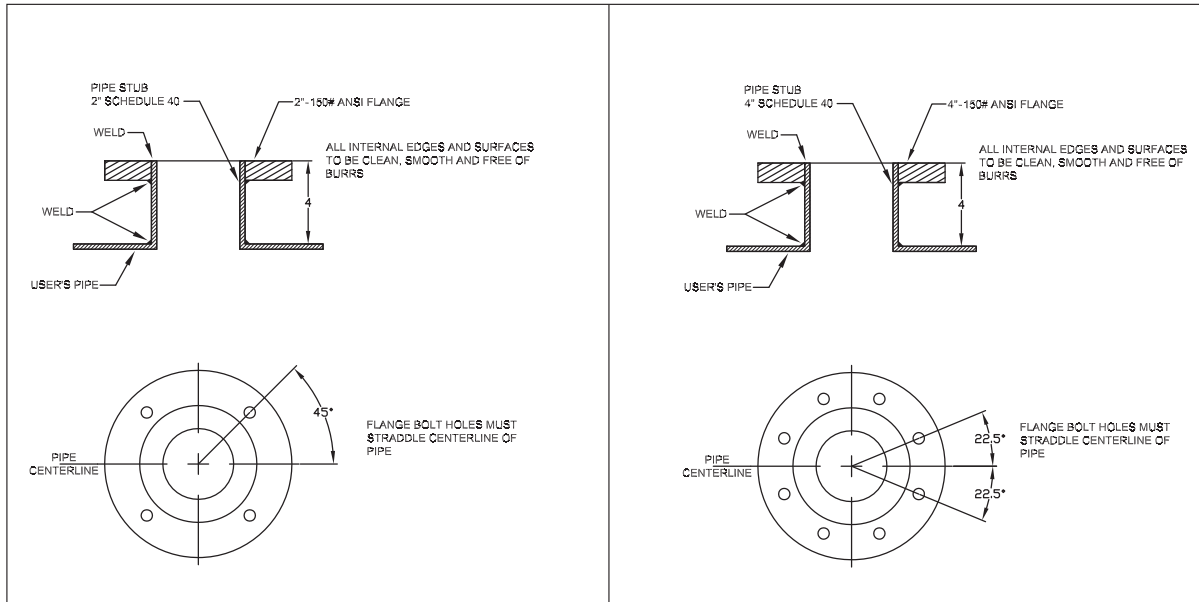

**FIGURE 6. FIXED INSERTION**

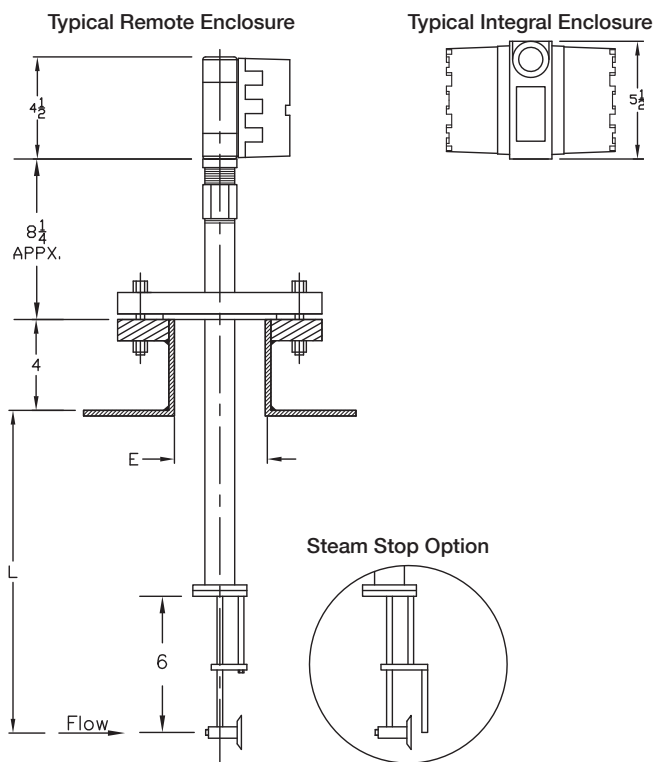

**RETRACTABLE PROBE MOUNTING**

**WARNING:** Do not turn the hand wheel, any knobs, or the lock bolts until instructed to do so. Read any tags and observe the precautions printed on them.

The ForceMeter™ must be preceded by at least twenty diameters of straight uninterrupted flow line and followed by a minimum of ten diameters. Ideally, the total length of straight pipe should be broken only where the flowmeter is inserted. Exceptions are full bore ball valves, small dead-end (no flow) pressure taps and thermowells. Steam traps should be located just ahead of and just beyond the straight run. If a bidirectional flow measuring unit has been ordered, the ForceMeter™ should have 20 diameters of straight pipe on each side of the meter unless the reverse flow accuracy is less important.

The use of steam traps, while at the option of the user, is strongly recommended in saturated steam systems. The use of the traps minimizes the accumulation of condensate in the bottom of the pipe. This accumulation changes the effective cross-sectional area of the pipe, introducing an error in the indicated flow rate. This condition affects all head-class flowmeters.

A gate valve or full-bore ball valve will be mounted to the stub flange, and the ForceMeter™ will be mounted to the valve. The retraction mechanism on the ForceMeter™ permits the sensing portion of the ForceMeter™

**FIGURE 7. RETRACTABLE PIPE MOUNTING**

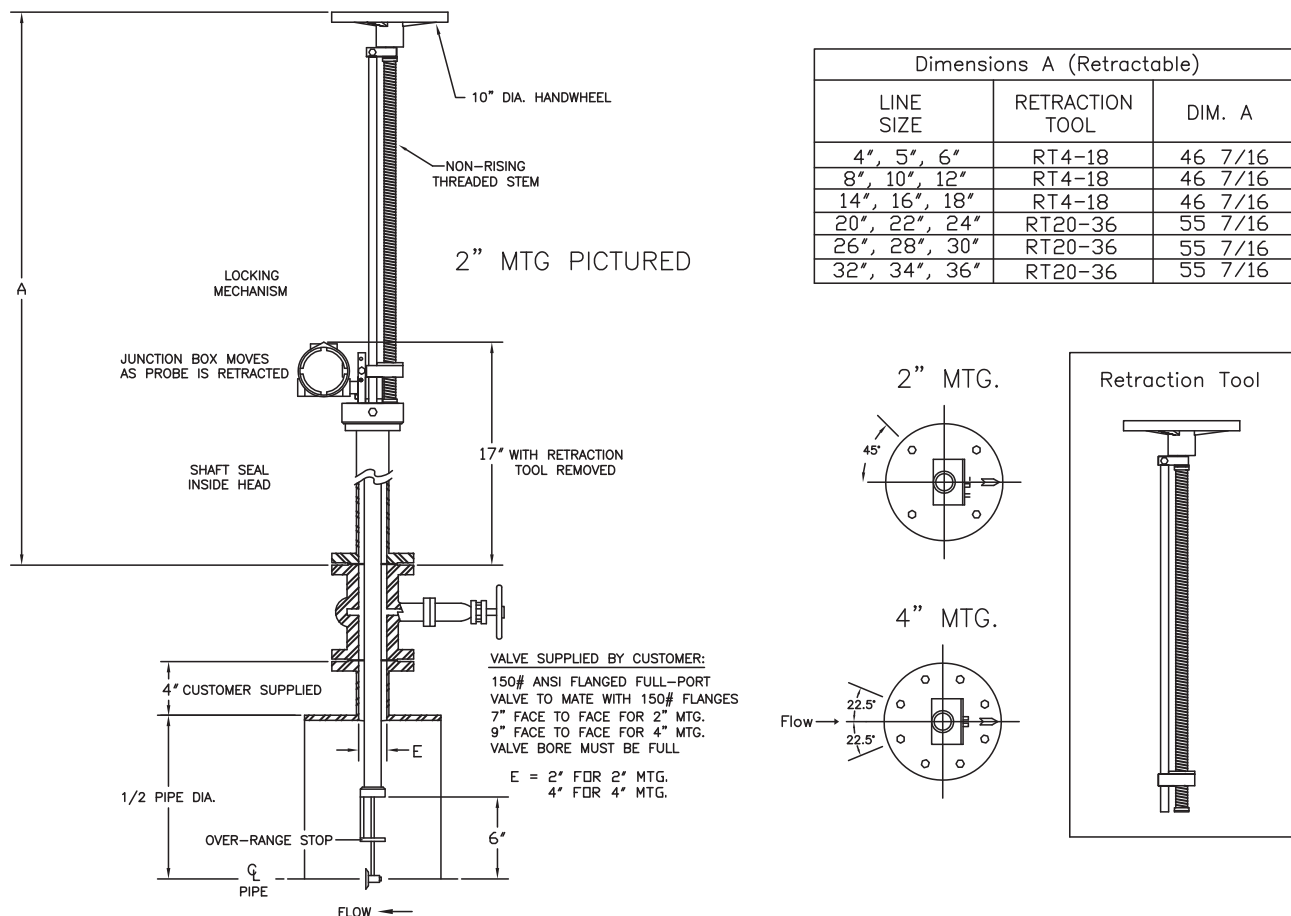

(the target) to be inserted or retracted while there is flow in the line. After retraction, the valve can be closed permitting removal of the ForceMeter™ without shutting down the pipeline.

For existing installations, it is possible to make a hot tap into a pipeline without shutting down the flow. After the cutting tool has been removed from the stub and valve, the ForceMeter™ can be installed.

The ForceMeter™ may be mounted in any position. The preferred position is with the pipe horizontal and the ForceMeter™ vertical. **SEE FIGURE 7. RETRACTABLE PIPE MOUNTING. NOTE:** For a horizontal pipe, if possible try to avoid the 4 to 8 o'clock position to prevent sediment particles that might restrict force measurement. This arrangement makes it easier for the installer to position the ForceMeter™ and align the gaskets. It is advisable for the customer to inform Niagara of the chosen mounting position when placing the order. Integral pressure and temperature sensors, if included, do not affect the piping requirements.

The target and its support will have to move into and out of the line freely. All of the parts through which the target passes should be in alignment with the stub flange. This includes the valve, the gaskets on both sides of the valve and flowmeter. This is particularly important if the ForceMeter™ is mounted horizontally.

Use four wooden dowels in the bolt holes to align the parts. The dowel diameter should be 3/32" greater than that of the bolts. Replace the dowels with the bolts, one at a time.

**NOTE:** For single unit orders with a Retraction Tool the tool is assembled on the meter. Refer to the ForceMeter™ outline drawing for location of the various flowmeter parts. See **FIGURE 8. PARTS LIST**. The lock bolt is to be inserted once the ForceMeter™ is placed into the line, it can be found attached to the main meter housing.

Multiple units are shipped with the Retraction Tool separated from the ForceMeter™. Bolts and lock washers (4 each) for assembling the tool to the meter can be found attached with a tie wrap to the hand wheel. The lock bolt, inserted once the ForceMeter™ is placed in the line, can be found attached to the ForceMeter™ main housing.

Before attaching the meter to the isolation valve, assemble the tool to the main housing. Raise the guide plate to the fully retracted position near the hand wheel. Locate the necessary hardware for mounting the retraction tool.

Insert the tie rods and threaded rod assembly into the main housing. Thread two larger screws (item 13, **FIGURE 8**) screws and split lock washers (item 16, **FIGURE 8**) through the main housing bolt holes into the tie rods and tighten securely. Using the hand wheel, bring the guide plate into the guide block. Using the two 1/4 (-20 x 1) screws (item 12, **FIGURE 8**) and 1/4 inch split lock washers (item 15, **FIGURE 8**), thread these through the guide plate into the guide block and tighten securely.

**BE SURE THE TARGET IS FULLY RETRACTED INTO THE MAIN HOUSING.**

After the isolation valve has been properly assembled to the flange stub, attach the ForceMeter™ and a gasket to the isolation valve using good quality stainless steel bolts. The flow arrow on the flange must be pointing in the direction of flow. On bidirectional units the arrow indicates forward flow. Be sure to use a gasket between the ForceMeter™ and the isolation valve.

When the bolts have been properly tightened, open the valve. Do not turn the hand wheel until the valve is

completely open. Turn the hand wheel until the target is inserted to the correct depth as indicated by the holes in the guide block and locking bar. Using the lock bolt 1/4 -20-1.5 (item 14, **FIGURE 8**) that was taken from the main housing when beginning the installation of the tool, put the lock bolt in place and tighten.

It is recommended that, after the flowmeter is inserted, a chain be threaded through the valve and flowmeter hand wheels. The chain should be locked and a tag applied stating, "Retract flowmeter before closing valve."

**CAUTION: AFTER INSTALLATION IF RETRACTING THE METER BE SURE THE TARGET IS WELL CLEAR OF THE ISOLATION VALVE BEFORE CLOSING THE VALVE.**

In some applications, the ForceMeter™ will be moved from one line to another. The ForceMeter™ limits this to 3 line sizes using the standard 4" mounting stub. The tool fits line sizes 4-18 inches or 20-36 inch line sizes in groups of 3. **SEE FIGURE 7. RETRACTABLE PIPE MOUNTING** for the sizes offered. Put the guide block in the correct position for the size selected, put the lock bolt in place and tighten.

**FIGURE 8. PARTS LIST**

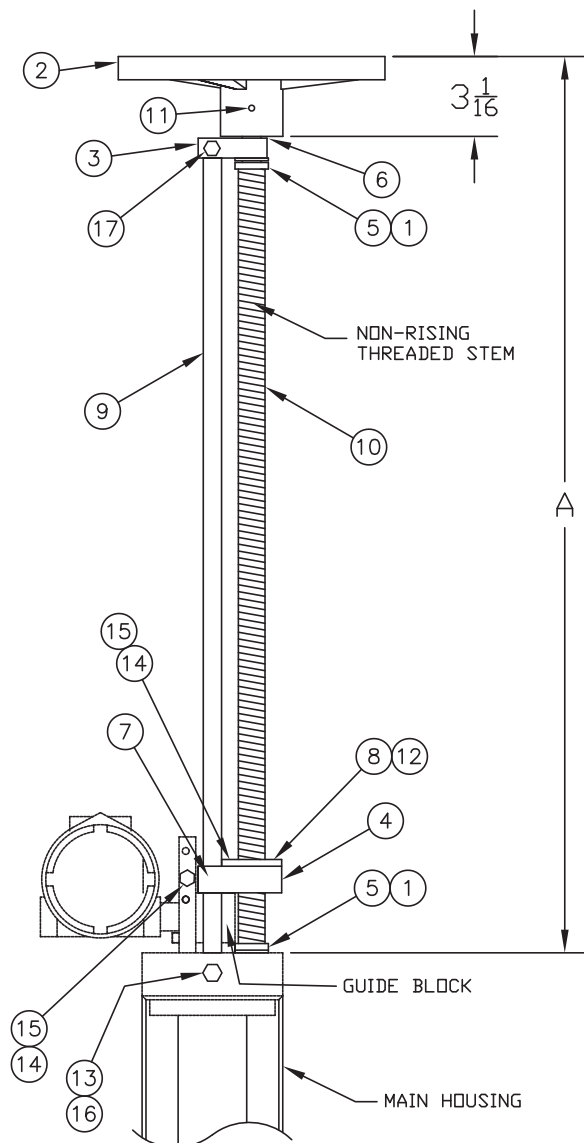

TOOL	TOOL
RT20-36	RT4-18
2	2
2	2
4	4
4	4
2	2
4	4
1	1
1	
	1
2	
	2
1	1
2	2
1	1
1	1
1	1
1	1
2	2
2	2
QTY	

LINE SIZE	RETRACTION TOOL	DIM. A (in inches)
4", 5", 6"	RT4-18	34 7/16
8", 10", 12"	RT4-18	34 7/16
14", 16", 18"	RT4-18	34 7/16
20", 22", 24"	RT20-36	43 7/16
26", 28", 30"	RT20-36	43 7/16
32", 34", 36"	RT20-36	43 7/16

Item List

QTY	DET.	DESCRIPTION
2	17	SCR HEX HD 1/4-20X1 18-8
2	16	LWSHR SPLIT SST 3/8 5000
4	15	LWSHR SPLIT SST 1/4X.062
4	14	SCR HEX HD 1/4-20X1.5
2	13	SCR HEXHD 18-8SS 3/8-16X1
4	12	SCR SDC HD18-8SS 1/4-20X1
1	11	PIN ROLL SST .250 X 1.5
1	10	STEM THRD 304S SIZE 36
	10	THRD STEM SIZE 18
2	9	TIE ROD SIZE 36
	9	TIE ROD SIZE 18
1	8	STEM NUT
2	7	BEARING ROD
1	6	BEARING FLANGED
2	5	BEARING WASHER
1	4	PLATE GUIDE
1	3	PLATE TOP
1	2	HANDWHEEL MACH (10" DIA.)
2	1	SCREW ST SDC 6-32X1/4 18-8

## VI. ELECTRICAL

The ForceMeter™ may be mounted in any position, but care must be taken to keep the electrical connections clean and moisture free. It is advisable to inform the manufacturer of the chosen mounting position when ordering. Protect all connections with a silicone moisture proof compound.

The target is a disc that has been accurately sized for the flow rate. Locate the target. The ForceMeter™ is shipped with the target retracted within the lower housing assembly. This protects it as the ForceMeter™ is being installed. In some installations the temperature sensor is in a small, sealed tube adjacent to the target. Both the target and the temperature sensor must not be handled roughly.

### INTEGRAL TRANSMITTER

For meters with integral transmitter mounting, remove the rear enclosure cover to access the 4-20mA loop connections. Connect the positive wire of the power source to the terminal block pin marked (+) and the negative (return) wire of the DC source to the terminal block pin marked (-). **SEE FIGURE 9. INTEGRAL TRANSMITTER WIRING.**

**FIGURE 9. INTEGRAL TRANSMITTER WIRING**

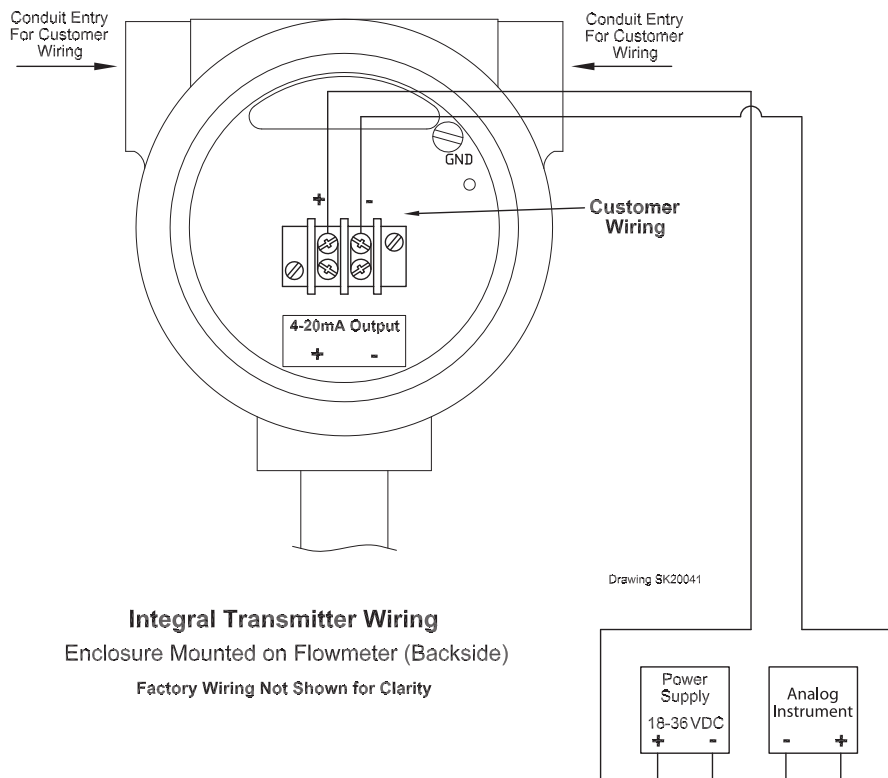

Analog Instruments used to monitor the 4-20 mA loop, **SEE FIGURE 9. INTEGRAL TRANSMITTER WIRING**, may have an internal sense resistor or require a sense resistor be placed in the loop and the instrument is then connected across it. Since the ForceMeter operates from a DC supply of 18-36 volts, the total loop resistance allowed (sum value of all sense resistors) is limited.

Use the following formula to calculate the minimum power supply voltage required for the given total loop resistance. Make sure that the applied loop voltage range is within the recommended 18-36VDC:

The Minimum Power Supply Voltage = 12 + (0.020 x Rs), where Rs is the total loop resistance.

Example: Assuming the internal sense resistor of the analog instrument is 500 Ohms, then minimum power supply voltage for proper operation of the transmitter is:

$$\text{Minimum Power Supply Voltage} = 12 + (0.020 \times 500) = 22 \text{ VDC}$$

The graph below shows the relationship between power supply voltage and total loop resistance.

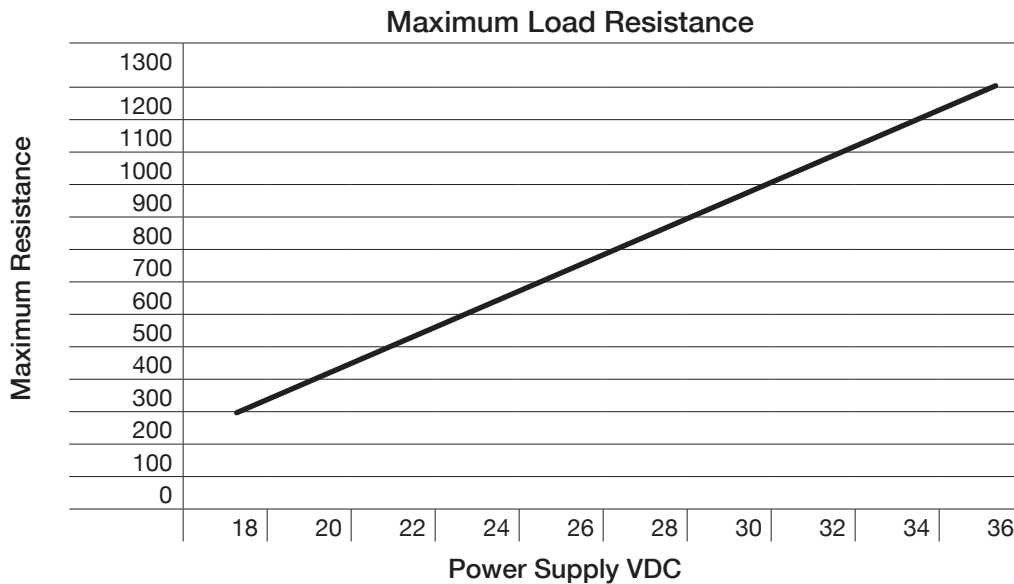

**REMOTE TRANSMITTER**

For remote mounted transmitters, remove the covers on the meter enclosure and transmitter enclosure to access the terminal strips. Use eight conductor cables (Beldin 8418 or equivalent) to connect the meter terminals to the transmitter terminals. The 4-20mA loop connections are accessible in the transmitter enclosure.

See **FIGURE 10. REMOTE TRANSMITTER WIRING.**

**FIGURE 10. REMOTE TRANSMITTER WIRING**

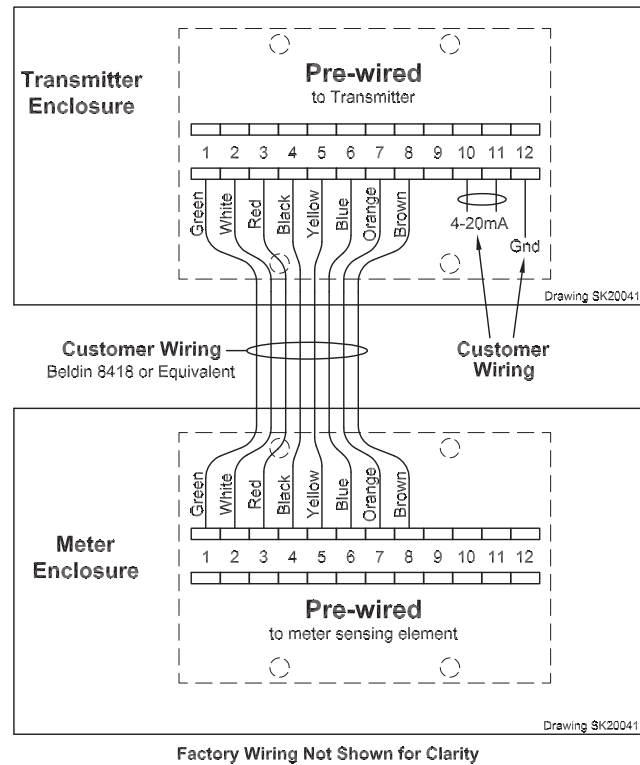

**HART COMMUNICATION**

The ForceMeter can be accessed using a variety of HART compliant devices.

See **FIGURE 11. HART WIRING.**

HART Protocols are available; please see target meter HART Protocol Guide.

The received value for the HART current sense resistor is 500 Ohms as shown in **FIGURE 11.**

To determine the minimum supply voltage, refer to the Minimum Power Supply equation. Remember that the value of the HART current sense resistor must be included in the total loop resistance.

**FIGURE 11. HART WIRING**

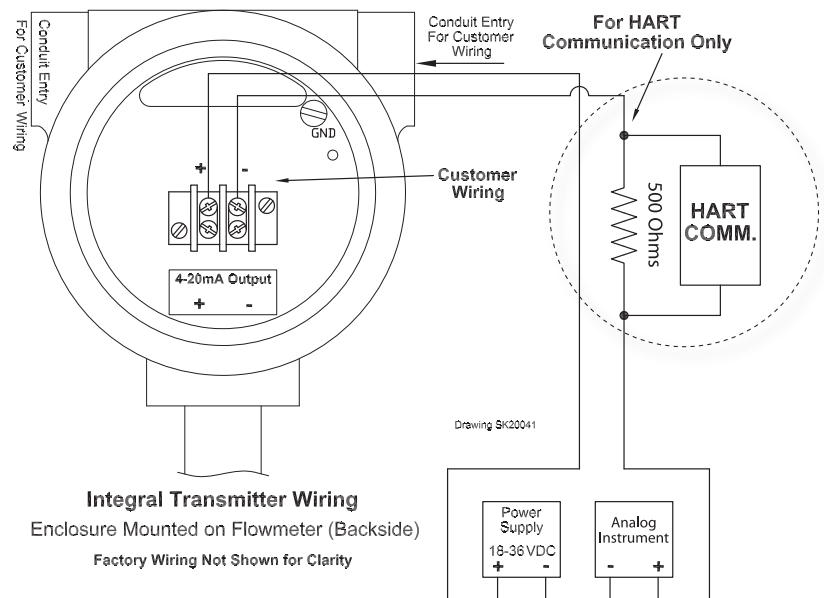

## VII. TRANSMITTER MENU OPTIONS

### DISPLAY DESCRIPTION

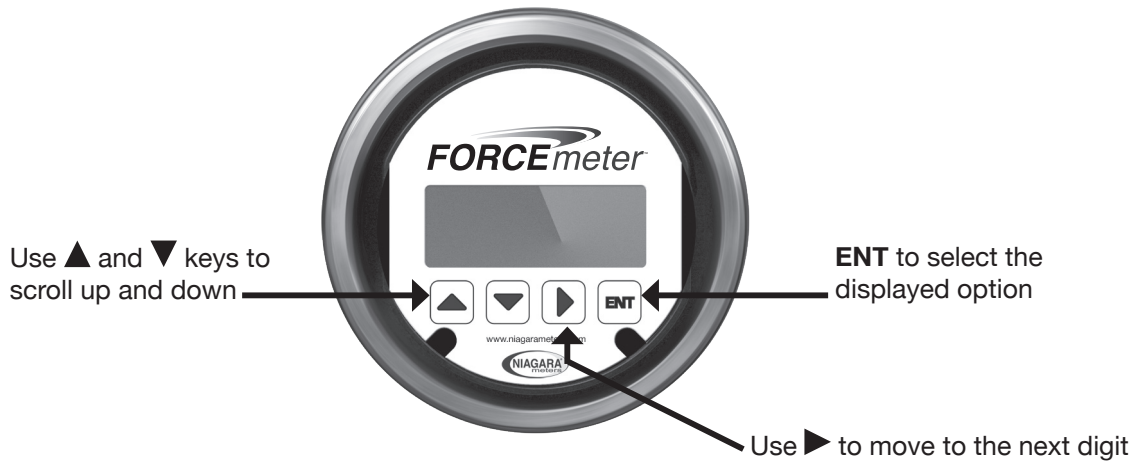

### ACCESSING THE MENU

1. Press **ENT** and ▲ simultaneously
2. Enter password. **Please Note:** Default password is 8960
3. Use the ▲ and ▼ keys to increment or decrement the selected digit
4. Use the ► key to select the next digit
5. Press **ENT** to accept the password

### ZEROING MODE

1. Press **ENT** and ▲
2. Enter password and press **ENT**
3. Menu will display:

**MAIN MENU**  
**EXIT**

4. Use the ▲ and ▼ keys until **ZERO METER** is displayed then press **ENT**
5. Menu will display:

**FLOW= ZERO?**  
**NO**

6. Use ▲ to select **YES**
7. Press **ENT**

**NOTE:** Display can be configured to display Rate and Total, Rate only, and Total only. What your display shows in operation mode depends on how your display is configured.



8. Menu will display:

**SET ZERO?**  
**NO**

9. Use ▲ to select **YES**

10. Press **ENT**

11. Once the meter is zeroed the menu will display:

**SET ZERO**  
**COMPLETE**

12. Menu will return to display:

**MAIN MENU**  
**ZERO METER**

13. Use the ▲ to scroll up for **EXIT**, then press **ENT**

14. Display will return to operation mode

**RESETTING TOTAL MODE**

In order to reset the total for the flow meter, access the Main Menu by entering the password information. See ACCESSING THE MENU section in this manual.

**MAIN MENU**  
**RST TOTAL**

Once the **RST TOTAL** option is selected by pressing **ENT** the meter will ask you to verify by selecting **YES** or **NO**.

Use the scroll arrows to select **YES** or **NO** and then press **ENT** to accept the selection.

If **NO** is selected the meter will return to the main menu where another selection can be made.

If **YES** is selected the meter will perform the reset and display **RST TOTAL COMPLETED** on the display before returning to the main menu.

**ACCESSING SIMULATE MODE**

In order to enter simulation mode for the flow meter, begin by accessing the Main Menu by entering the password information. See ACCESSING THE MENU section in this manual.



Press **ENT** to select simulate mode. The **SIMULATE** menu options are:

- 4mA to force 4mA output
- 8mA to force 8mA output
- 12mA to force 12mA output
- 16mA to force 16mA output
- 20mA to force 20mA output

Once the output is selected press **ENT**.

An ( \* ) will be placed by that output signal indicating this is the chosen signal.

To end simulation, press the arrow keys until BACK is available and press **ENT**.

**ACCESSING PROGRAM MODE**

Please consult manufacturer before changing program settings.

In order to enter program mode for the flow meter, begin by accessing Main Menu by entering the password information. See ACCESSING THE MENU section in this manual.

In Program Mode change Flow Type, Units, Range settings, Calibration, Display options, etc.



Once **PROGRAM** is displayed on the meter, press **ENT** to select.

The PROGRAM menu options are:

- |                               |                |
|-------------------------------|----------------|
| • BACK (returns to main menu) | • CUSTOM SCALE |
| • FLOW TYPE                   | • SET CAL      |
| • RATE UNIT                   | • DECIMAL      |
| • TOTL UNIT                   | • SPECIAL      |
| • RANGE SET                   | • BIDIRECT     |

## VIII. PROGRAM MODE INFORMATION

### FLOW TYPE:

To change Flow Type from volumetric or mass flow, scroll to **MASS** or **VOLUME** and press **ENT**. Once a selection is made an ( \* ) will appear next to that selection made indicating which flow type has been selected. Once a selection has been made, scroll to the **BACK** option and press **ENT** to go back to the Main Menu.

### RATE UNIT:

The Rate Unit is the engineering units to be displayed for flow rate on the meter. Selection choices for rate unit vary based on flow type. Scroll to the desired units and press **ENT**. The meter will place an ( \* ) next to the selected option. Scroll to **BACK** option once a selection has been made to return to the main menu.

**FIGURE 12. RATE OPTIONS FOR VOLUMETRIC FLOW**

UNIT	DESCRIPTION	UNIT	DESCRIPTION
GPS	gallons/second	CFH	cubic feet/hour
GPM	gallons/minute	CFD	cubic feet/day
GPH	gallons/hour	BPS	barrels/second
GPD	gallons/day	BPM	barrels/minute
MGD	mega gallons/day	BPH	barrels/hour
LPS	liters/second	BPD	barrels/day
LPM	liters/minute	IGS	imperial gallons/second
LPH	liters/hour	IGM	imperial gallons/minute
MLD	mega liters/day	IGH	imperial gallons/hour
CMS	cubic meters/second	IGD	imperial gallons/day
CMM	cubic meters/minute	NCH	normal cubic meter/hour
CMH	cubic meters/hour	NLH	normal liter/hour
CMD	cubic meters/day	%	percentage
CFS	cubic feet/second	SCM	standard cubic feet/minute
CFM	cubic feet/minute		

**FIGURE 13. RATE OPTIONS FOR MASS FLOW**

UNIT	DESCRIPTION	UNIT	DESCRIPTION
GPS	grams/second	PPS	pounds/second
GPM	grams/minute	PPM	pounds/minute
GPH	grams/hour	PPH	pounds/hour
KPS	kilograms/second	PPD	pounds/day
KPM	kilograms/minute	STM	short tons/minute
KPH	kilograms/hour	STH	short tons/hour
KPD	kilograms/day	STD	short tons/day
MTM	metric tons/minute	LTH	long tons/hour
MTH	metric tons/hour	LTD	long tons/day
MTD	metric tons/day	%	percentage

**TOTAL UNIT:**

The Total Unit is the engineering units to be displayed for the Totalizer on the meter. Selection choices for the Total Unit vary based on Flow Type. Scroll to the desired units and press **ENT**. The meter will place an ( \* ) next to the selected option. Scroll to **BACK** option once a selection has been made to return to the **PROGRAM** menu.

**FIGURE 14. TOTAL OPTIONS FOR VOLUMETRIC FLOW**

UNIT	DESCRIPTION	UNIT	DESCRIPTION
GAL	gallon	CF	cubic feet
LIT	liter	CL	cubic liter
IGL	imperial gallon	BBL	bbl liquid
CM	cubic meter	NCM	normal cubic meter
BL	barrel	NL	normal liter
BSL	bushel	SCF	standard cubic feet
CY	cubic yard	HL	hectoliters

**FIGURE 15. TOTAL OPTIONS FOR MASS FLOW**

UNIT	DESCRIPTION	UNIT	DESCRIPTION
G	grams	ST	short tons
KG	kilograms	LT	long tons
MT	metric tons	OZ	ounces
LB	pounds		

**RANGE SET:**

The Range Set option scales the 4-20mA output to the process variable. In order to set the Range Set scroll to the Range Set option on the Program Menu and press **ENT**. Use the arrow keys to display the options. Selection choices for Range Set vary based on the direction of the meter.

Unidirectional Meter Options:

- 4mA
- 20mA
- CUT OFF

Initial range values are 4mA = 0 flow and 20mA = Full Scale flow designated by the invoice and application process. For a Unidirectional Meter the Cut Off will be the minimum flow that can be reported by the meter.

Bidirectional Meter Options:

- MaxRange
- CUT OFF

The 4mA option will be the output when flow reaches this value in reverse direction. The Max Range option is the output when flow reaches this value in the positive direction. CUT OFF which is a process variable that allows the meter to report zero flow in both forward and reverse flow.

**CUSTOM SCALE:**

The Custom Scale option is a percentage between 90 and 110, which can be selected to change the output factor to be displayed and transmitted. Select the desired option and press **ENT** to return to the **PROGRAM** menu.

**SET CAL:**

The Set Cal option is set at the factory to match the transmitter to the target meter. This must not be changed without first consulting the factory.

**DECIMAL:**

This option allows the decimal location that is displayed to be selected. The options are:

- 000000
- 0000.0
- 000.00

**NOTE:** The number of decimal digits will be limited by the full-scale value.

Scroll to the desired display option and press **ENT**. The meter will place an ( \* ) next to the selected option. Scroll to **BACK** option once a selection has been made to return to the **PROGRAM** menu.

**SPECIAL**

- METER INFO will sequence through the serial number, firmware version, and model numbers, etc. that are assigned to the meter.
- CHANGE PW is the option to change the password for the meter
- DEFAULT resets the meter back to the original factory defaults set when the meter was shipped.
- FAULT HIST shows all the faults and warnings history that had occurred in meter during operation.
- CLR FAULT clears all active faults stored in the meter.
- TRIM provides an option to trim 4mA and 20mA output independent of flow.
- DAMPING provides an option to manage the displayed flow rate and mA output caused by severe turbulence or other conditions. Possible settings are 0-99 where 1 =0.333 seconds, 2=.666 seconds, 3=0.999 seconds, 90=29.97 seconds. The default setting is 3.
- DISPLAY provides the option to select the parameters to display on the meter. Standard is Flow Rate and Total. Options include Rate Only and Total Only.
- FAILSAFE provides the option to select the value the 4-20mA is to transmit in the case there is a failure. Starting value is always ON LOW. Possible values are ON LOW, ON HIGH, and ON OTHER. Where ON LOW is 3.5mA, ON HIGH is 22.5mA, and ON OTHER is between 4mA and 20mA.

**BIDIRECT:**

The Bidirect mode allows the meter to be set in unidirectional or bidirectional flow. Scroll to **NO** for unidirectional and **YES** for bidirectional flow. Scroll to the desired display option and press **ENT**. The meter will place an ( \* ) next to the selected option. Scroll to **BACK** option once a selection has been made to return to the **PROGRAM** menu. This option is only available with a bidirectional meter. Please consult order information.

## IX. CALIBRATION

Except for extreme conditions, no calibration is required.

Due to fast response of the ForceMeter™, flow fluctuations and transients may be seen which cannot be detected by other systems of flow measurement. What may appear to be instability in the ForceMeter™ may actually be instability in the fluid system. The flow range of any instrument may be altered, within certain limits, by the installation of a new target. Do not disassemble the sealed sensing element, as any unauthorized repairs will void the manufacturer's warranty.

### FIELD CALIBRATION

**NOTE:** This is for unidirectional meters; for bidirectional, consult factory.

An important feature of the ForceMeter™ is the ease with which the retention of calibration accuracy can be verified in the field. By removing the ForceMeter™ from the line and making two simple checks, it can readily be determined whether the calibration is unchanged. In addition to the normal components of the flow system, the following is required: (a) a digital multimeter capable of reading milliamps, (b) a precision vernier caliper or micrometer and (c) a weight of known mass.

At the time the ForceMeter™ is calibrated by the manufacturer, the calibration parameters (including the target diameter and the full scale force) are recorded on the data sheet and supplied with the ForceMeter™. These are also stored in the transmitter (Special Menu/Meter Info). If these measurements are unchanged, the calibration is unchanged. The sensor body (disc-shaped target) is sized and the edge contoured to obtain a desired drag in the moving stream of fluid. Comparison of the diameter of the disc at its edge with the diameter as measured when calibrated will show whether the drag is unchanged. The effect of the drag is to produce a force on the target support rod, resulting in an electrical output signal from the strain gage transducer in the ForceMeter™. The relationship of the force on the rod to the signal is called the force factor and is a measure of the system sensitivity. A comparison of the force factor to that recorded when calibrated will show whether the sensitivity is unchanged.

To make the field checks, the ForceMeter™ should be removed from the line and the target removed from the support rod that is the upstream face of the target. At this time, the diameter can be measured using a vernier caliper or micrometer. Note: On bi-directional targets, both the upstream and downstream edges should be measured if the Target Type is SPIR. The target size listed on the data sheet includes a number which is the diameter of the target in thousandths of an inch. For example ACR-405 is a target with a diameter of 0.405".

**Note:** On inline units it is advisable to carefully replace the o-ring when reassembling the meter into its housing.

With the target still removed, fasten a thin wire to the rod at the point where the center of the target would be. Then clamp the ForceMeter™ so that the forward flow direction is truly vertical and acting downward. Connect the ForceMeter™ per the wiring instructions in section ELECTRICAL. Connect the digital multimeter and apply power.

Before hanging a weight, record the programmed settings for Custom Scale and Cal 1 through Cal 8. These will need to be returned to their initial values after performing the field calibration test. Refer to Accessing the Menu programming section CUSTOM SCALE and SET CAL.

Custom Scale = \_\_\_\_\_

Change Custom Scale to 100

Do Not change Cal 1, Cal 2, Cal 6, Cal 7 or Cal 8

After recording Custom Scale Cal 3, Cal 4 and Cal 6 change to 500

Cal 1 = \_\_\_\_\_

Cal 2 = \_\_\_\_\_

Cal 3 = \_\_\_\_\_

Cal 4 = \_\_\_\_\_

Cal 5 = \_\_\_\_\_

Cal 6 = \_\_\_\_\_

Cal 7 = \_\_\_\_\_

Cal 8 = \_\_\_\_\_

Zero the meter using the procedure in the section ZEROING THE METER. Using the digital multimeter, 4mA should be displayed. This output signal is the zero load output. Hang a known weight, the full-scale weight, from the thin wire. Record the resulting test load output signal as indicated on the digital multimeter.

- If equal to the full-scale weight the milliamp output should read 20 mADC.
- If less than the full-scale weight calculate the theoretical mADC output:

$$\left( \sqrt{\frac{\text{Weight Used}}{\text{Full-Scale Weight}} \times 16} \right) + 4$$

If this reading is within 2-3% of that given, then the ForceMeter™ is operating with its original calibration. Small variances in calibration can be due to differences in measuring equipment, positioning compared to factory, etc.

If readings are greater than 3%, or if you prefer specific settings, please refer to APPENDIX 5.

Return Custom Scale and Cals 1- 8 to the recorded numbers.

## X. TROUBLESHOOTING

The transmitter has a built-in self-diagnostic program which will display any faults being experienced by the unit. When there is a fault, the current will go to the fail-safe selected current and a message on screen says “FAULT X” where the X is the code number of the current fault. All possible faults are listed below:

**FIGURE 16. SELF-DIAGNOSTIC FAULT CODES**

FAULT CODES	DESCRIPTION	ACTION TO TAKE
1	Internal 2.5V reference voltage	Check whether stable DC power is connected to transmitter. Clear fault from Failsafe to RUN mode. If fault appears again after clearing then contact manufacturer.
2	Internal 1.25V reference voltage	See Action for Fault Code 1.
3	Bridge excitation voltage	See Action for Fault Code 1.
4	Not Used	-
5	Bridge connector not plugged in	Connect Bridge to Transmitter. Please clear fault to switch from Failsafe to RUN mode.
6	Bridge element fault (open/short)	See Action for Fault Code 1.
7	Not Used	-
8	AD12 communication	See Action for Fault Code 1.
9	D POT communication	See Action for Fault Code 1.
10	Not Used	-
11	AD24 communication	See Action for Fault Code 1.
12	Not Used	-
13	Not Used	-
14	Flash read error	See Action for Fault Code 1.
15	Flash write error	See Action for Fault Code 1.
16	Not Used	-
17	Processor main clock failure	See Action for Fault Code 1.
18	Processor aux. Clock failure	See Action for Fault Code 1.
19	Not Used	-
20	Internal 2.5V reference voltage warning	Please check whether stable DC power is connected to Transmitter.
21	Internal 1.25V reference voltage warning	Please check whether stable DC power is connected to Transmitter.
22	Bridge operating temperature over/under range	Device detected fluid temperature more than it can handle. Please refer specification of device.
23	Process variable over/under flow	Device detected flow range more/below than Transmitter can handle. Please refer specification of device. Please clear fault to switch from Failsafe to RUN mode.
24	Bridge RTD failure	See Action for Fault Code 1.



## **XI. MAINTENANCE AND REPAIR**

The ForceMeter™ is not designed to be serviced by customers. Please consult the manufacturer.

## **XII. WARRANTY**

A manufacturer's limited equipment warranty applies. Please consult the terms and conditions provided at the point of sale for a full description of the manufacturer's warranty. For a generic version of the warranty please consult the manufacturer.

## XIII. APPENDICES

### 1. THEORY

The instantaneous output of the strain gage bridge,  $E_{rl}$ , is directly and linearly proportional to the force,  $F$ , exerted on the target by the fluid flow. (Units defined at end of this section.)

$$E_{rl} = \frac{K}{2.2046} F$$

The total drag on any three dimensional body suspended in a fluid stream, gas or liquid, is the sum of the frictional drag and the pressure drag.

$$F_{total} = F_{frictional} + F_{pressure}$$

The frictional drag is equal to the integration of the shear stresses along the boundary of the body in the direction of the general motion of the fluid stream. The pressure drag is equal to the integration of the components in the direction of motion of all pressure forces acting on the bodies surface. Pressure drag is the dynamic component of the stagnation pressure acting on the projected area of the immersed body normal to flow.

When considering an equation to describe the response of the ForceMeter™, only total drag is of interest and the equation becomes:

The total force due to turbulent fluid flow is proportional to the velocity head:  $\frac{V^2}{2g}$

$$F_t = C_d A \rho \frac{V^2}{2g}$$

This equation applies to fluid flows where turbulence exists over the complete flow range of interest. Turbulence will exist in the vicinity of the target when the pipe Reynolds Number ( $R_D$ , see equation below) is 2000 or greater and will predominate throughout the pipe cross-section when  $R_D$  is 2000 or greater. The value of  $R_D$  above which turbulence will exist is approximate, since turbulence is dependent on pipe roughness, entrance conditions and other factors. If, at the low end of the flow range  $R_D$  is 2000 or greater, the output is unaffected by variations in fluid viscosity and affected only by changes in fluid density ( $\rho$ ). If at the low end of the flow range,  $R_D$  is between 1000 and 2000, the output for that part of the flow range may be affected by viscosity.

Laminar flow exists below  $R_D = 400$  and a transition range exists between 400 and about 2000. The drag coefficient of the target ( $C_d$ ) may vary in an unpredictable manner when  $R_D$  is in the transition or laminar regions. The low  $R_D$  can be brought about by low flow, high viscosity or both.

Although behavior in these regions may not always be predictable, it is repeatable if the flow conditions are held constant. An actual flow calibration by the manufacturer can be provided to cover conditions such as those described.

The ForceMeter™ conditions the signal from the strain gage bridge described above and yields a 4-20mADC output signal linear to flow. The bridge is excited using an AC excitation that minimizes thermocouple effects. On units with an integral RTD thermal stability is achieved compensating for temperature changes with the ForceMeter's electronics and additional firmware.

A ForceMeter™ can be calibrated with one fluid and then used with another fluid without loss of precision if the

data are corrected for density change and the viscosities of both fluids are closely similar to keep  $R_D$  within the same range. With all other factors constant, electrical output will vary directly with fluid density.

Volumetric Units

$$Q_2 = Q_1 \frac{S_1}{S_2}$$

Gravimetric Units

$$W_2 = W_1 \frac{S_2}{S_1}$$

Pipe Reynolds Number is computed from any of the equalities below.

$$R_D = R_D = 50.6 \frac{Q_1 \rho}{d \mu} = 6.31 \frac{W}{d \mu} = 3160 \frac{Q_1}{dV}$$

- F = Applied Force in pounds
- $F_t$  = Total Drag force
- $C_d$  = Drag coefficient
- A = Area of target (sq. ft.)
- $\rho$  = Fluid density, pounds per cubic ft.
- V = Velocity through meter bore (ft. per second)
- $E_1$  = Voltage output at calibration
- $E_2$  = Voltage output, corrected for operating conditions
- $S_1$  = Specific gravity at calibration
- $S_2$  = Specific gravity of operating fluid
- $R_D$  = Reynolds number, for unobstructed pipe
- $Q_1$  = Rate of flow, gallons per minute
- $Q_2$  = Corrected rate of flow, gallons per minute
- $W_1$  = Rate of flow, pounds per hour
- $W_2$  = Corrected rate of flow, pounds per hour
- d = Internal diameter of meter bore (inches)
- $\nu$  = Viscosity, centistokes
- $\mu$  = Viscosity, centipoise
- g = Gravitational constant = 32.2 feet/second/second
- K = Force factor, millivolts per volt of excitation, per kilogram of force
- $E_{r1}$  = Instantaneous voltage ratio output in millivolts/volt of excitation
- $Z_1$  = Super compressibility factor of original gas
- $Z_2$  = Super compressibility factor of new gas

## 2. VISCOSITY

Two distinct types of flow in pipe are normally referred to – laminar and turbulent. Laminar flow is characterized by cylindrical layers of fluid which glide smoothly over each other. A dye injected in laminar flow would travel in straight lines. In turbulent flow the particles of fluid travel in a random motion. A dye injected in a turbulent situation would be dispersed throughout the pipe. The situation in which flow is in the process of change between laminar and turbulent or vice versa is referred to as, the transition zone.

In the target ForceMeter™, the force exerted on the target by flow is given by the following:

$$F = C_d A \rho \frac{V^2}{2g}$$

This equation applies to flows where turbulence exists over the complete flow range. Should the flow fall into the transition or laminar regions, the force exerted is given by different formulas. Therefore, if the ForceMeter™ is calibrated for use in turbulent flow and subsequently used in laminar or transition flow, the output from the ForceMeter™ will no longer be a square function as given by the above formula. However, an actual flow calibration can be provided to cover these conditions. To know when this special calibration is required, there must be a means of determining when laminar or transition flow will exist. This can be determined by calculating the pipe Reynolds number.

Reynolds number is the dimensionless combination of the pipe diameter and density, viscosity and velocity of flow. Put another way, it is the ratio of the dynamic forces of flow to the shear forces due to viscosity:

$$R_D = \frac{DV\rho}{\mu}$$

A simplified form would be:

$$R_D = \frac{3160Q_1}{dv}$$

Where  $Q_1$  = flow rate in gpm

$d$  = internal pipe diameter in inches

Turbulence will exist in the vicinity of the target when the pipe Reynolds number is 2000 or greater. Laminar flow exists below  $R_D = 400$  and a transition range exists between 400 and 2000. These numbers are approximate since pipe roughness, entrance conditions and other factors influence the condition of the flow.

If throughout the flow range the Reynolds number is greater than 2000, the ForceMeter™ output will be unaffected by variations in fluid viscosity. A water flow calibration will adequately describe the conditions of flow. For Reynolds numbers less than 2000 a special calibration is required which simulates the conditions of flow. In other words, viscosity has an unpredictable yet repeatable effect at Reynolds numbers less than 2000. The Reynolds number of the special calibration is made to match the customer's Reynolds number so that the unpredictable effects of viscosity are determined. It should be noted that the customer's viscosity must be maintained in order to maintain calibration accuracy. The change to a different viscosity requires a new calibration.

### 3. CORRECTION FACTORS FOR VOLUMETRIC GAS FLOW

#### RATE WHEN OPERATING CONDITIONS CHANGE

A flow meter calibrated for use with a specified gas at given conditions of temperature and pressure can often be used to measure the flow rate when the operating conditions are changed. A change to a different gas can often be accommodated too.

There are three limitations:

- Do not apply higher pressures and/or higher temperatures that are beyond the limits of the flow meter internal design or the rating of the end connections. Check the flow meter data sheet.
- When the operating gas pressures exceed 100 psig, the ideal gas laws do not apply and the equations below must be modified by a super-compressibility correction factor. Refer to standard handbooks covering gas flows, or consult the manufacturer.
- The new operating conditions must not cause the indicated flow rate to go beyond the original flow range. If it would, check with the manufacturer on having the flow meter re-ranged.

Gas flow rates can be expressed two ways: (1) in ACFM, the actual cubic feet per minute of gas flowing at the operating temperature and pressure, or (2) in SCFM, the “standard” cubic feet per minute flowing at the operating temperature and pressure. The SCFM is a standard reference and indicates the flow rate in cubic feet per minute if the same weight of gas had been flowing at the “standard” conditions: 14.7 psia and 60° F.

When the flow being measured uses a different gas or the operating conditions are changed, then the indicated flow rate must be multiplied by a correction factor to obtain the new flow rate. Choose the correction factor from the equations below depending on the units used in the original calibrations and the units desired for the new flow rate.

Original in SCFM – New in SCFM:

$$V_2 = V_1 \sqrt{\frac{G_1 P_2 T_1 Z_1}{G_2 P_1 T_2 Z_2}}$$

Original in ACFM – New in ACFM:

$$V_2 = V_1 \sqrt{\frac{G_1 P_1 T_2 Z_2}{G_2 P_2 T_1 Z_1}}$$

Original in SCFM – New in ACFM:

$$V_2 = V_1 \frac{14.696}{519.67} \sqrt{\frac{G_1 T_1 T_2 Z_1 Z_2}{G_2 P_1 P_2}}$$

Original in ACFM – New in SCFM:

$$V_2 = V_1 \frac{519.67}{14.696} \sqrt{\frac{G_1 P_1 P_2}{G_2 T_1 T_2 Z_1 Z_2}}$$

$V_1$  = indicated volumetric flow rate (equal to true flow rate at original calibration)

$V_2$  = volumetric flow rate at new conditions

$G_1$  = specific gravity of original gas

- G<sub>2</sub> = specific gravity of new gas
- P<sub>1</sub> = original pressure of gas at operating conditions, psi absolute
- P<sub>2</sub> = new pressure of gas at operating conditions, psi absolute
- T<sub>1</sub> = original temperature of gas at operating conditions, degrees Rankine
- T<sub>2</sub> = new temperature of gas at operating conditions, degrees Rankine
- Z<sub>1</sub> = super compressibility factor original calibration
- Z<sub>2</sub> = super compressibility factor new conditions

**Note:** Below 150 psi Z can be ignored.

(Degrees Rankine = degrees F + 459.67)

**Note:** Standard conditions are considered to be 14.696 PSIA and 60°F (519.67° R).

Air = 0.0764 lbs/ft<sup>3</sup>

Water = 62.3714 lbs/ft<sup>3</sup>

**Note:** If any of the three parameters, specific gravity, pressure or temperature are unchanged eliminate that parameter from the equations.

#### 4. CORRECTION FACTORS FOR STEAM FLOW RATE

A ForceMeter™ calibrated for use with steam at given conditions of temperature and pressure can often be used to measure the flow when the operating conditions change. There are two limitations:

- Do not apply higher pressures and/or temperatures that are beyond the limits of the ForceMeter™ internal design or the rating of the end connections. Check the flow meter data sheet.
- The new operating conditions must not cause the indicated flow rate to go beyond the original flow range. If it would, check with the manufacturer on having the ForceMeter™ re-ranged.

When the steam operating conditions change, then the indicated flow rate must be multiplied by a correction factor to obtain the new flow rate:

$$W_2 = W_1 \sqrt{\frac{Vg_1}{Vg_2}}$$

W<sub>1</sub> = indicated rate of flow, pounds per hour

W<sub>2</sub> = flow rate at new conditions, pounds per hour

Vg<sub>1</sub> = specific volume of steam at original conditions

Vg<sub>2</sub> = specific volume of steam at new conditions

**5. CORRECTIONS FOR CHANGE IN FORCEMETER™ SENSITIVITY**

At the time a ForceMeter™ is calibrated by the manufacturer, among the measurements made and recorded on the data sheet supplied with the ForceMeter™ is the force factor and full-scale weight. The force factor is a measure of the system sensitivity and arrived at by hanging a known weight, preferably 1 kilogram, from the lever arm of the ForceMeter™ element at the point where the target is attached and recording the corresponding output in mADC. A change in the force factor of a calibrated ForceMeter™, usually due to the replacement of the primary element, will affect the accuracy of the ForceMeter™. However, a correction factor can be applied to the Custom Scale for a change in the system sensitivity thereby retaining the calibration accuracy.

Please refer to section FIELD CALIBRATION.

The force factor correction (K) is equal to the ratio of the forces:

$$K = \frac{F_1 - 4}{F_2 - 4}$$

Where  $F_1$ , Original mADC =  $\left( \sqrt{\frac{\text{Weight Used}}{\text{Full-Scale Weight}} \times 16} \right) + 4$

Where  $F_2$  is New Measured mADC

If the reading with a known weight yields a milliamp reading greater than the calculated theoretical mADC, the meter has become more sensitive . If the mADC is less, it has become less sensitive. To make a correction multiply the Custom Scale by K.

Example for finding a Correction Factor:

The Full-scale Weight is 820 kg, the Weight Used is 700 kg, and the Custom Scale is 100.

$$\left( K = \frac{18.783 - 4}{19.960 - 4} \right) \times 100 = \text{Correction Factor of } 92.63\%$$

Where  $F_1$ , Calculated mADC =  $\left( \sqrt{\frac{700}{820} \times 16} \right) + 4 = 18.783 \text{ mADC}$

Where  $F_2$ , New Measured mADC = 19.960

**NOTE:** If Custom Scale is greater than 110 or less than 90, then STOP and consult factory.



150 Venture Boulevard  
Spartanburg, SC 29306  
Tel: 800.778.9251  
Fax: 864.574.8063  
E-mail: [sales@niagarameters.com](mailto:sales@niagarameters.com)  
[www.niagarameters.com](http://www.niagarameters.com)

**venture**  
MEASUREMENT

2012 All rights reserved.  
All data subject to change without notice.  
FM 2011 0700 Rev. C